

# PORTABLE ALUM. VEHICLE TWIN RAMPS - VTR-6-14-18

APPROX WEIGHT: 747.74 lbs.  
DOES NOT INCLUDE WEIGHT OF POWER OR PACKAGING!!!

\*\*\* ANY ADDITIONS, DELETIONS, OR OMISSIONS MUST BE CORRECTED ON THIS DRAWING AS THIS DRAWING WILL BE CONSIDERED ALL INCLUSIVE \*\*\*

ALL GRAPHICS PROVIDED ARE FOR REFERENCE ONLY. IF CERTAIN DIMENSIONS ARE CRITICAL PLEASE VERIFY THOSE DIMENSIONS WITH YOUR SALESPERSON

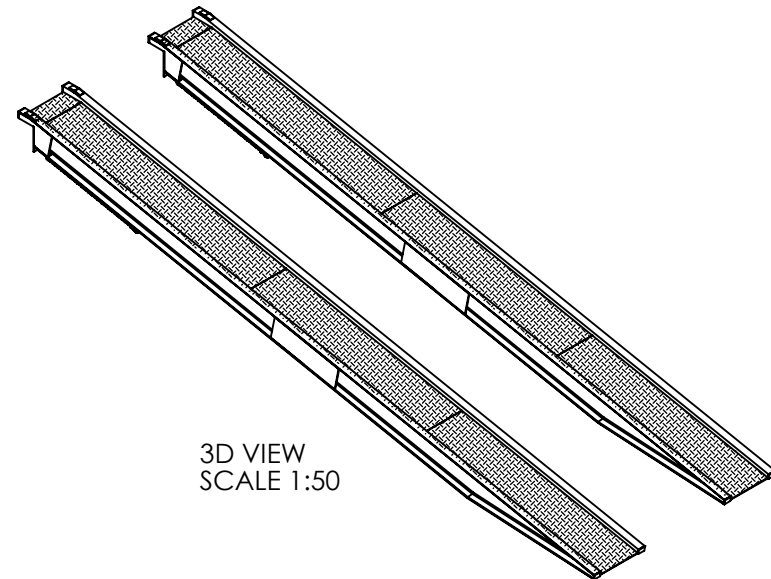
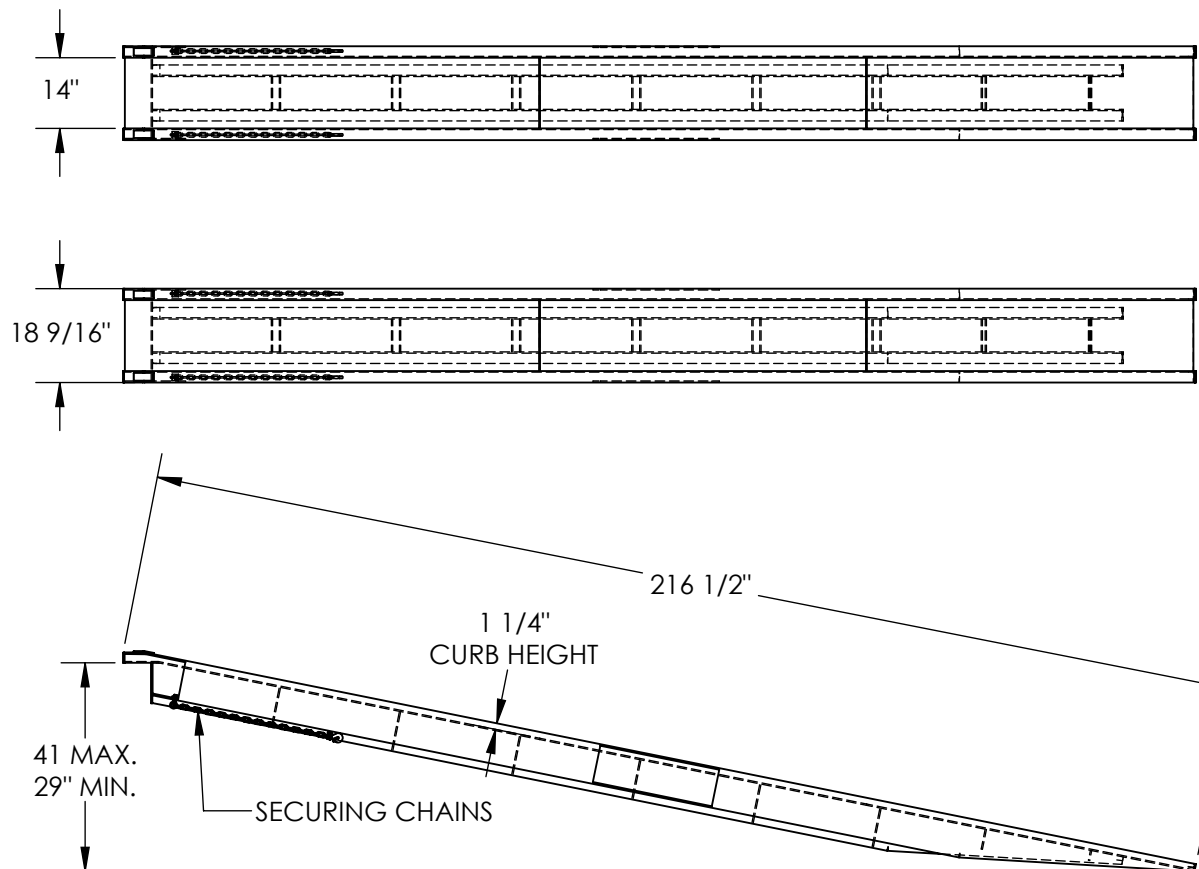

DIMENSION TOLERANCE ± 1/4"

## STANDARD FEATURES

- MODEL NUMBER IS VTR-6-14-18
- OVERALL WIDTH IS 18 9/16"
- USABLE RAMP WIDTH IS 14"
- LENGTH IS 216 1/2"
- MAX. WORKING HEIGHT IS 41"
- MIN. WORKING HEIGHT IS 29"
- MAX. LOAD CAPACITY (PER PAIR) IS 6,000 LBS.
- 1 1/4" CURB HEIGHT
- INCLUDES 2 SECURING CHAINS
- WELDED ALUMINUM CONSTRUCTION

## SPECIAL FEATURES

NONE

**A P P R O V A L**

I, THE UNDERSIGNED, AGREE THAT THE PRODUCT AS REPRESENTED SATISFIES DESIGN AND DIMENSION REQUIREMENTS. I ALSO ACKNOWLEDGE MY DUTY TO CONFIRM PRODUCT AND INSTALLATION COMPLIANCE WITH ALL APPLICABLE FEDERAL, STATE AND LOCAL REGULATIONS AND STANDARDS.

**ANY MODIFIED UNITS ARE NON-RETURNABLE**

As drawn       As marked

Signed: \_\_\_\_\_ Date: \_\_\_\_\_

Printed Name: \_\_\_\_\_

LEAD TIME WILL START UPON RECEIPT OF SIGNED APPROVAL DRAWING

FOR INTERNAL USE ONLY PROJECT SIGN OFF	
SALES	
ENG.	
FAB.	
POWER	

DISTRIBUTOR'S NAME:		P.O.#
VESTIL MANUFACTURING		X
DRAWN BY: TJM	DATE: 08/05/15	W.O.#
REFERENCE: X	SCALE: 1:38	X
QUOTED LEAD TIME: X	QUOTE #	FILE NAME:
	X	18-007-305