

PORTABLE ALUM. VEHICLE TWIN RAMPS - VTR-7-14-8

APPROX WEIGHT: 174.26 lbs.
DOES NOT INCLUDE WEIGHT OF POWER OR PACKAGING!!!

*** ANY ADDITIONS, DELETIONS, OR OMISSIONS MUST BE CORRECTED ON THIS DRAWING AS THIS DRAWING WILL BE CONSIDERED ALL INCLUSIVE ***

ALL GRAPHICS PROVIDED ARE FOR REFERENCE ONLY. IF CERTAIN DIMENSIONS ARE CRITICAL PLEASE VERIFY THOSE DIMENSIONS WITH YOUR SALESPERSON

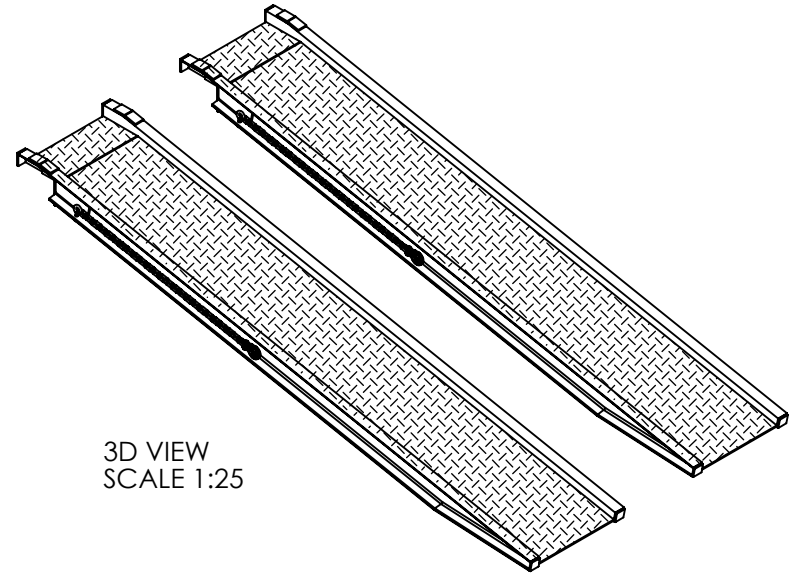
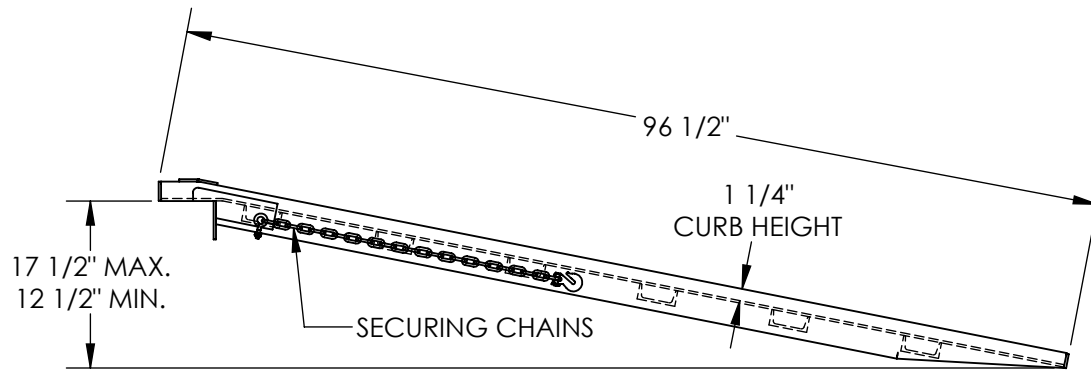
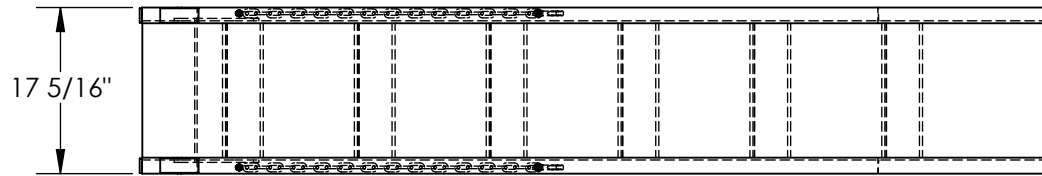
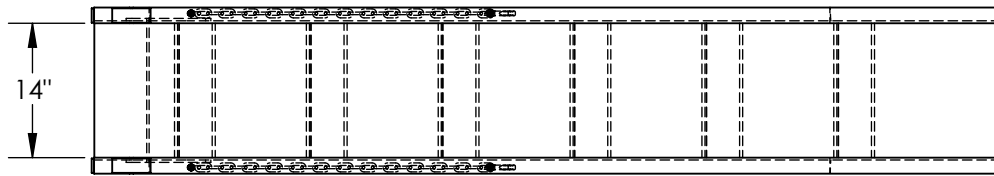

3D VIEW
SCALE 1:25

DIMENSION TOLERANCE $\pm 1/4"$

STANDARD FEATURES

- MODEL NUMBER IS VTR-7-14-8
- OVERALL WIDTH IS 17 5/16"
- USABLE RAMP WIDTH IS 14"
- LENGTH IS 96 1/2"
- MAX. WORKING HEIGHT IS 17 1/2"
- MIN. WORKING HEIGHT IS 12 1/2"
- MAX. LOAD CAPACITY (PER PAIR) IS 7,000 LBS.
- 1 1/4" CURB HEIGHT
- INCLUDES 2 SECURING CHAINS
- WELDED ALUMINUM CONSTRUCTION

SPECIAL FEATURES

NONE

FOR INTERNAL USE ONLY PROJECT SIGN OFF	
SALES	
ENG.	
FAB.	
POWER	

A P P R O V A L

I, THE UNDERSIGNED, AGREE THAT THE PRODUCT AS REPRESENTED SATISFIES DESIGN AND DIMENSION REQUIREMENTS. I ALSO ACKNOWLEDGE MY DUTY TO CONFIRM PRODUCT AND INSTALLATION COMPLIANCE WITH ALL APPLICABLE FEDERAL, STATE AND LOCAL REGULATIONS AND STANDARDS.

ANY MODIFIED UNITS ARE NON-RETURNABLE

As drawn As marked

Signed: _____ Date: _____

Printed Name: _____

LEAD TIME WILL START UPON RECEIPT OF SIGNED APPROVAL DRAWING

DISTRIBUTOR'S NAME:		P.O.#
VESTIL MANUFACTURING		X
DRAWN BY: TJM	DATE: 11/14/14	W.O.#
REFERENCE: X	SCALE: 1:20	X
QUOTED LEAD TIME: X	QUOTE #	SALES: X
	X	FILE NAME:
		18-007-300