

MODEL NAME - WEB-W-15

APPROX WEIGHT: 2.70 lbs.
 DOES NOT INCLUDE WEIGHT OF POWER OR PACKAGING!!!

*** ANY ADDITIONS, DELETIONS, OR OMISSIONS MUST BE CORRECTED ON THIS DRAWING AS THIS DRAWING WILL BE CONSIDERED ALL INCLUSIVE ***

ALL GRAPHICS PROVIDED ARE FOR REFERENCE ONLY. IF CERTAIN DIMENSIONS ARE CRITICAL PLEASE VERIFY THOSE DIMENSIONS WITH YOUR SALESPERSON

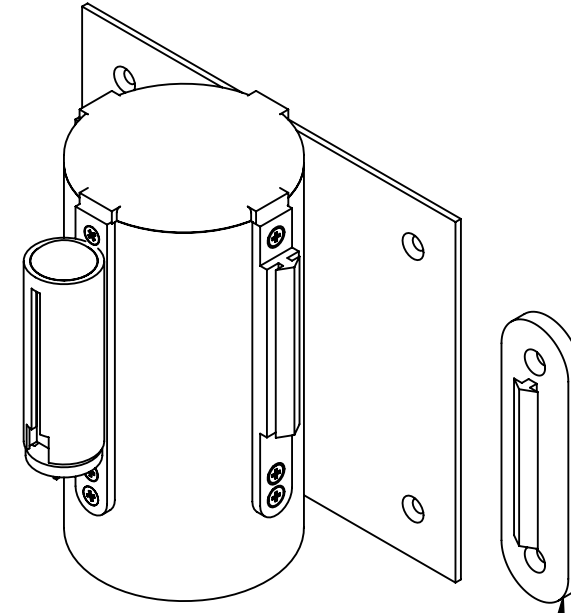
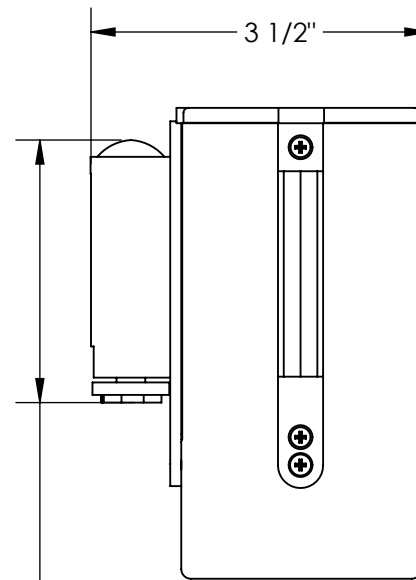
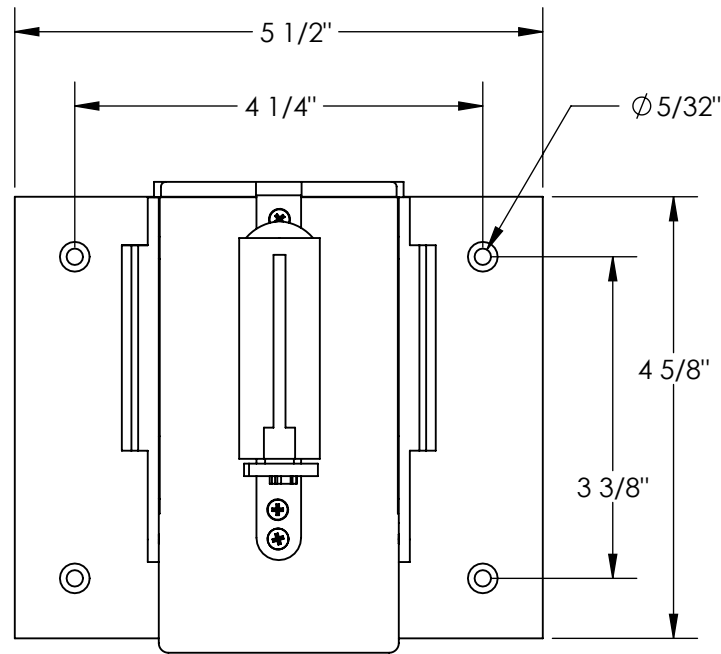

WALL MT. WEB RECEPTICAL

NOTE: WEB-W WILL MATCH OTHER VESTIL FLOOR MT PERSONAL BARRIERS

2 3/4"

STANDARD FEATURES

- MODEL NUMBER IS WEB-W-15
- WALL MOUNTED UNIT WITH RECEPTACLE
- INCLUDES 15' YELLOW FABRIC WEB
- WEB END WILL ATTATCH TO WALL MOUNTED RECIEVER OR ANOTHER FLOOR MOUNTED BARRIER
- WEB COLOR IS YELLOW
- WEB LENGTH IS 15'
- WEB WIDTH IS 1 1/2"
- WALL MT. WEB RECEPTICAL (INCLUDED)

SPECIAL FEATURES

APPROVAL	I, THE UNDERSIGNED, AGREE THAT THE PRODUCT AS REPRESENTED SATISFIES DESIGN AND DIMENSION REQUIREMENTS. I ALSO ACKNOWLEDGE MY DUTY TO CONFIRM PRODUCT AND INSTALLATION COMPLIANCE WITH ALL APPLICABLE FEDERAL, STATE AND LOCAL REGULATIONS AND STANDARDS.	
	ALL SPECIAL UNITS ARE NON-RETURNABLE	
	[] As drawn [] As marked	
Signed: _____		Date: _____
LEAD TIME WILL START UPON RECEIPT OF SIGNED APPROVAL DRAWING		

DISTRIBUTOR'S NAME:		P.O.#
VESTIL MANUFACTURING		X
DRAWN BY: WHR		DATE: 5/15/12
REFERENCE: X		SALES: X
QUOTED LEAD TIME: X		SCALE: 1:2
QUOTE # X		FILE NAME: 30-007-250