

Stockpicker Trucks Survey Sheet - SPS2

Inquiry Date: _____ Due Date: _____
Contact: _____
Company: _____
Phone: _____
Fax: _____
E-mail: _____

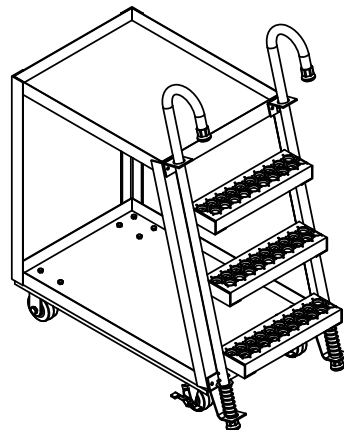

PLATFORM SIZE

Not Critical

Overall Width: _____
 Overall Length: _____
 Usable Width: _____
 Usable Length: _____

Cart Requirements:

Not Critical

Caster Size: _____
 Caster Material: _____
 Caster Brakes: _____
 Deck Material: _____
 Deck Ht. (From Floor): _____
 Push Handle: _____

PRODUCT INFO

Load / Product type:
 Basket / Pallet / Gaylord / Skid
 Other: _____
 Product Size:
 Length: _____
 Width: _____
 Height: _____
 Does container have feet? _____
 Does container have drop sides? _____
 Yes / No

Application / Loading Info:

Application Information:

Number of shifts: _____
 Special Temperature requirements: _____
 Side Loading: _____
 Special Loading and Unloading Requirements: _____

Additional Notes:

Quote options:

_____ Exactly as specified _____ Cheapest / Closest to Vestil standard
 _____ Quickest to ship
 Requested Delivery Date: _____

*All options may not be available on all models

Vestil Manufacturing Company * Angola, IN 46703 * Ph- 260-665-7586 * Fx- 260-665-1339