

POWERED STACKER WITH POWER DRIVE, POWER LIFT, & POWER FORK REACH

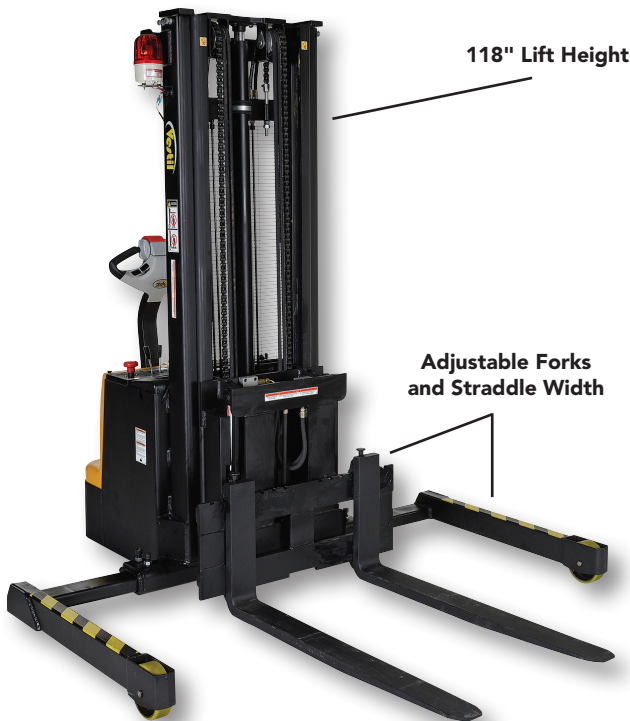

118" Lift Height

Adjustable Forks and Straddle Width



Fork Reach Up To 25"

Standard Features:

- Designed to use in narrow or confined spaces.
- Equipped with extendable forks, which can be utilized to reach 25".
- Power driven with controls that allow for precise positioning.
- Throttle with thumbwheel offers forward/reverse speeds.
- Includes fingertip raise/lower buttons.
- Safety belly emergency reverse function.
- Features 24V/0.5 KW drive and 24V/2.0 KW lift motor.
- Rolls smoothly on poly-on-steel steer and load wheels.
- Features two (2) 12V lead acid batteries with an integral charger and battery level gauge.

Powered Fork Reach



MODEL NUMBER	FORK SIZE (W x L)	SERVICE RANGE	FORKS	*UNIFORM CAPACITY 2" - 62" RH	*UNIFORM CAPACITY 62" - 118" RH	WEIGHT (LB)
S-118-AA-FR	26¾" x 36¼"	2½" to 118"	RETRACTED	1,500 lb.	1,000 lb.	1836
			EXTENDED	800 lb.	600 lb.	

*Uniform capacity with forks retracted and extended at specific raised height

Ideal for distribution and shipping facilities!



Vestil Manufacturing Corporation
Larissa Flora - Sales Representative

2999 North Wayne Street, P.O. Box 570
Angola, Indiana 46703, USA

Phone: (260) 624-4341 Fax: (260) 665-1339
E-Mail: larissa@vestil.com Web: www.vestil.com